



## LED Retrofit 40W E27



### Product Overview

LED retrofit lamps are direct replacements for conventional incandescent, halogen, and compact fluorescent (CFL) lamps.

LEDs deliver higher lumens per watt (lm/W) which means significant energy savings while lasting more than ten times longer than incandescent sources. With their directional light, instant on and ability to dim, LEDs are fast becoming the light source of choice.

### Features

- Light even distribution.
- More eco-valued.
- Wider beam angle.

### Safety and Maintenance

- Switch off supply before installing or removing lamp.
- Allow to cool before handling.
- Do not use in totally enclosed fittings as this will reduce lamp life.
- Do not dispose of in household waste.
- Dispose of in appropriate section of local civic amenity site or recycling centre.

## Specifications – E27 Cap

|                                   |                            |
|-----------------------------------|----------------------------|
| Item Code                         | S19996                     |
| Leedarson model                   | P-SVCFB1ap004JA-NNN0470C27 |
| Part number in certificate/report | S19996                     |
| Lamp Cap                          | E27                        |
| Rated Power (W)                   | 3.8                        |
| Equivalent Wattage (W)            | 40                         |
| Rated Luminous Flux (lm)          | 470                        |
| CCT (K)                           | 2700                       |
| Beam Angle                        | 320°                       |
| Dimmable                          | NO                         |
| Rated Lifetime (h)                | 15000                      |
| Switching Cycles                  | 40000                      |
| Input Voltage                     | 220-240V~50/60Hz           |
| Current (mA)                      | 40                         |
| Chip Type                         | LED                        |
| Chip Brand                        | MTC                        |
| Mercury Free                      | YES                        |
| CRI                               | 80                         |
| SDCM                              | /                          |
| Dimenesion (D*H)mm                | 76*45                      |
| Product Weight (g)                | 17                         |
| Power Factor                      | 0.4                        |
| Rated Peak Candelas (cd)          | /                          |
| Starting Time (S)                 | <0.5                       |
| Warm-up time to 60% (S)           | <1                         |
| Instant light                     | YES                        |
| Ambient Temperature Range (°C)    | (-20°C~40°C)               |
| Clean-up instructions             | See website                |
| Retrofit                          | Yes                        |

## Energy Label – E27 Cap

|                                |     |
|--------------------------------|-----|
| Energy Class                   | E   |
| Energy Consumption (kWh/1000h) | 3.8 |

\* The kWh/1000h value published on the energy label is required to be rounded up to an integer according to the EU implementing directive on Energy Labelling. The value to 2 decimal places is given for reference.

## Product Markings — E27Cap

|                   |                  |
|-------------------|------------------|
| Voltage           | 220-240V~50/60Hz |
| Nominal Power (W) | 3.8              |
| Current (mA)      | 40               |
| CE Mark           | Yes              |
| WEEE Mark         | Yes              |
| Batch Code        | Yes              |

Dimensions

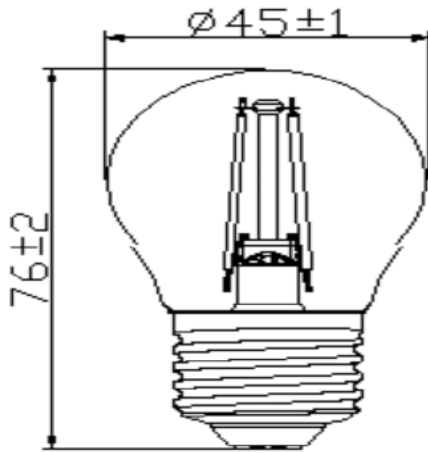

S19996

Photometric Information

2700K

